

RESEARCH OF THE INTERNATIONAL EXPERIENCE OF ARRANGEMENT OF PROVING GROUNDS PASSABLE TERRAIN FOR WHEELED AND TRACKED MILITARY VEHICLES

Tamaz Natriashvili¹ Paata Dolidze² Roman Kenkishvili³ Vakhtang Mamaladze⁴

DOI: <https://doi.org/10.61446/ds.1.2022.6453>

Licensed under: CC BY

Article History:

Received 23 January 2022

Accepted 18 February 2022

Published 05 April 2022

Abstract

The article presents the project data of construction designs for an estimation of passability of wheeled and tracked military vehicles for checking the parameters that are accepted as obligatory within the North Atlantic Treaty Organization (NATO). In particular, the constructions for determining the following parameters of passability are considered: ground clearance; angles of approach and departure; angle of climb; minimum turning radius; corridor width while turning with minimum radius; maximum angles of overcome gradients and side slope; maximum width of overcome vertical-sided ditch; maximum heights of overcome vertical wall and step; drawbar pull, speed and acceleration during mobility on the soft soil; and maximum depth of overcome water during fording.

The project data is selected from the data of proving grounds for wheeled and tracked military vehicles and the relevant documents of the USA and the Russian Federation so that they don't come in a contradiction with publications of the NATO.

Keywords: Wheeled vehicle, tracked vehicle, passability, parameters of passability, proving ground.

¹ Doctor of Technical Sciences, Director of LEPL Raphael Dvali Institute of Machine Mechanics

² Ph.D., Chief Research Scientist of Heat Power Installations Department of LEPL Raphael Dvali Institute of Machine Mechanics

³ Doctor of Engineering Sciences, Head of Heat Power Installations Department of LEPL Raphael Dvali Institute of Machine Mechanics

⁴ Master of Science, Research Assistant of Machine Building Department of LEPL Raphael Dvali Institute of Machine Mechanics

INTRODUCTION

It is known that the passability of the vehicle determines its ability to move at bad road conditions, on off-road terrain and overcome different obstacles. All vehicles must have a characterization of passability, but various types of vehicle require different passability depending on purpose. For example, high-class passenger car is intended for moving only on the quality roads; therefore, it does not require any special passability. Trucks that are used to work on both good and bad roads and off-road terrain must have increased passability. It is natural that the passability has particular importance for military vehicles. Until the present, there are no common criteria by which it could be possible to estimate the complete passability; therefore, passability is estimated by means of comparative estimation of the ability of the vehicle to overcome difficult passable areas and various obstacles. If a vehicle is more passable, than more its average speed of performing of transport work in bad road conditions, off-road terrain and overcoming an obstacle.^{5,6}

MAIN PART

The vehicle can lose a moving ability due to some factors such as touching of vehicle projection parts with uneven surface of the road, danger of overturning on side slopes, impossibility of climbing gradients, insufficient adhesion of wheels or vehicle sinkage in the surface, dampening of vehicle electrical devices or penetration of water in the air inlet during fording and so on. Taking the noted factors into consideration, nomenclature of the military vehicle passability parameters can be expressed by the following way: ground clearance; angles of approach and departure; angle of climb; minimum turning radius; corridor width while turning with minimum radius; maximum angles of overcoming gradients and side slopes; maximum width of overcoming vertical-sided ditch; maximum heights of overcoming vertical wall and step; drawbar pull, speed and acceleration during mobility on the soft soil; and maximum depth of overcoming water depth during fording.^{7,8}

Parameters like ground clearance, angles of approach and departure, andw angle of climb are determined on a flat, level area, with hard cover (wood, concrete, asphalt and so on). If it is possible the area should be covered. The possible limits of the unevenness of the support surface is 3 mm, and inclination from horizontal - 5.

Minimum turning radius and corridor width while turning with minimum radius can be determined on the area element shown on figure 1. Figure 2 shows section and plan view of this area.^{9,10}

⁵ Dvali R. Theory of operational properties of the vehicle. Tbilisi, Tbilisi University Publishing House, 1986 2 Агейкин Я. С. Проходимость автомобилей. М.: Машиностроение, 1981.

⁶ Агейкин Я. С. Проходимость автомобилей. М.: Машиностроение, 1981.

⁷ AVTP 1. Allied vehicle testing publications.

⁸ ГОСТ РВ 52048-2003. Автомобили многоцелевого назначения. Параметры проходимости и методы их определения. 5 AVTP 01-10. Dimension and profile.

⁹ AVTP 03-30. Steering and Manoeuvrability.

¹⁰ TOP 01-1-011A. Vehicle Test Facilities at Aberdeen Test Center and Yuma Test Center.



Fig. 1. An air photo of the area element for the determination of turning radii.

The gradients to be overcome by vehicles are arranged on hard, equal ground. It is allowed to cover them by artificial materials. The gradient complex for testing the vehicle passability consists of different gradients with 3060 percent slopes. The gradient slope must be constant in length – it must be no less than twice the overall length of the vehicle. Acceptable inclination from constant slope is 5 percent. The testing gradients must have areas for turning the vehicles at both sides. Figure 3 represents the orientation scheme of the proving ground gradeability slopes. The given scheme unites gradients for testing the passability on the 30-, 40-, 45-, 50- and 60 percent slopes and Table 1 gives their orientation project data. Figure 4 shows the illustration of gradients with different slopes.^{11,12,13}

Fig. 2. Section and plan view of turning circle.

¹¹ AVTP 03-90. Gradients and Slopes.

¹² TOP 01-1-011A. Vehicle Test Facilities at Aberdeen Test Center and Yuma Test Center.

¹³ ГОСТ РВ 52048-2003. Автомобили многоцелевого назначения. Параметры проходимости и методы их определения.

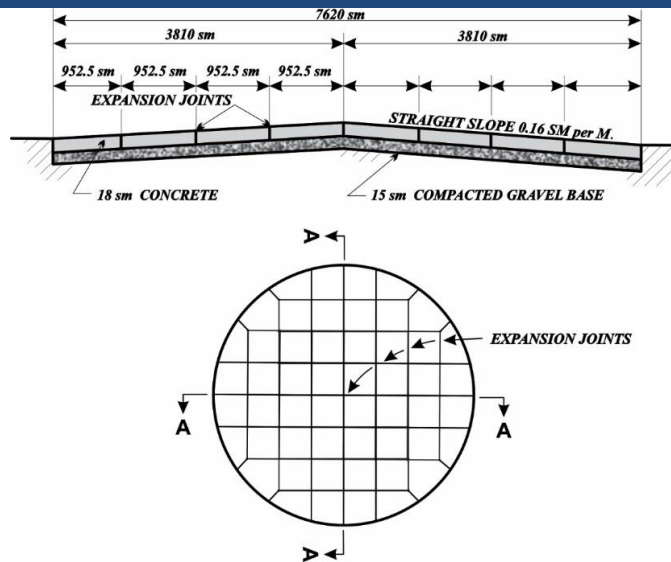

Fig. 3. Orientation scheme of the proving ground gradeability slopes

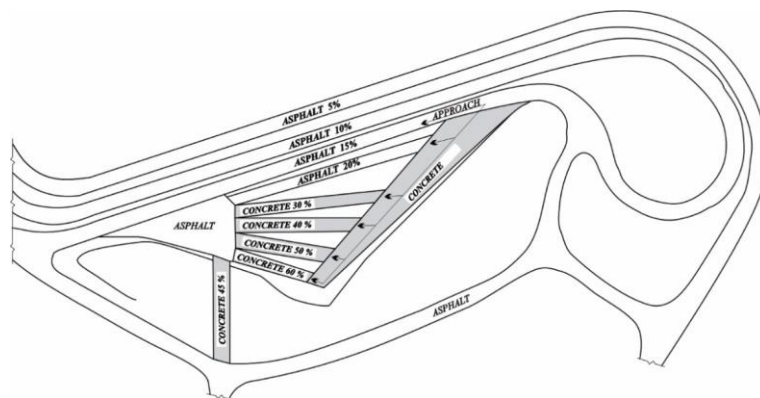

Table 1.

Orientation project data of the passability testing gradients.

No	Gradient slope (percent)	Carriageway length (m)	Material used for road cover
1	30	45	concrete
2	40	34	concrete
3	45	18	concrete
4	50	30	concrete
5	60	25	concrete

The side slopes to be overcome by vehicles are arranged on hard, equal ground. It is allowed to cover them by artificial materials. The side slope complex for testing the vehicle passability consists of different slopes with 20- 30- and 40 percent inclination. The side slope must be constant in the length and it must be no less than three times the overall length of the vehicle. Acceptable inclination from constant slope is 5 percent. Figure 5 and figure 6 represent 30 percent side slope transverse section and its illustration. Table 2 shows the orientation project data of side slopes.^{14,15,16}

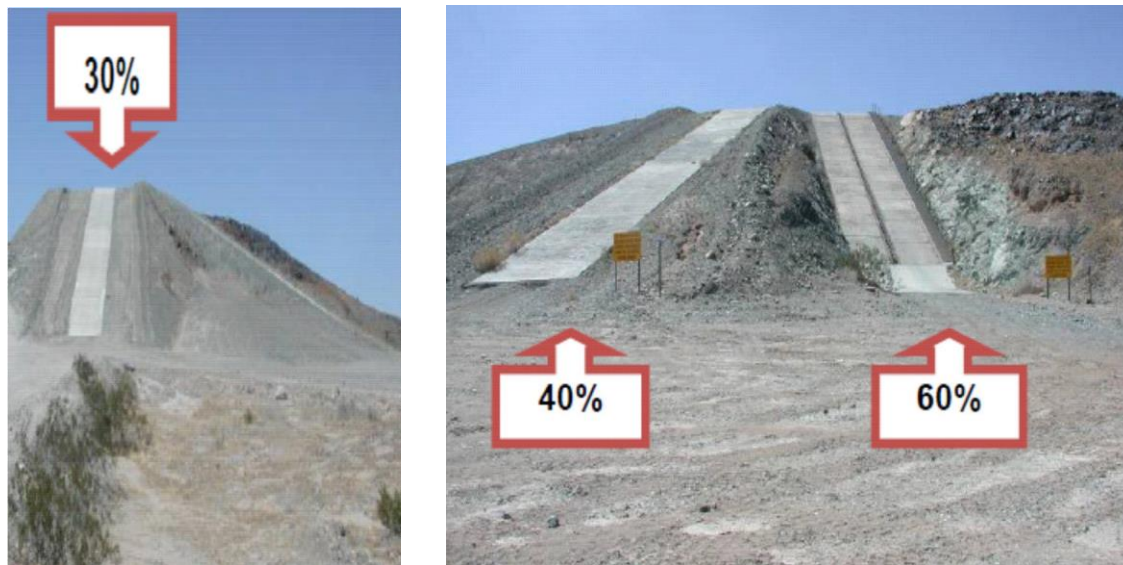
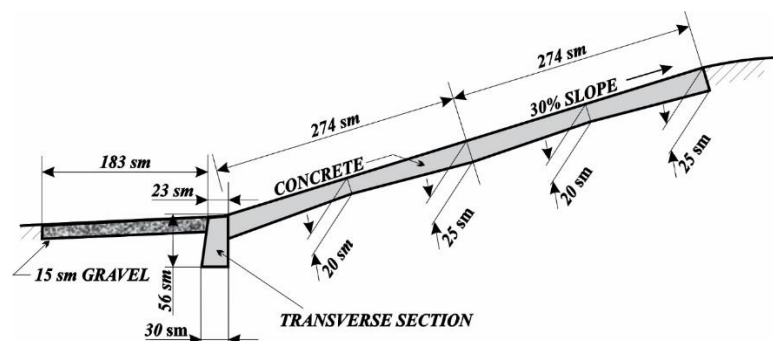

Fig. 4. 30 - percent grade (left) and 40 and 60 - percent grades (right).



¹⁴ AVTP 03-90. Gradients and Slopes.

¹⁵ TOP 01-1-011A. Vehicle Test Facilities at Aberdeen Test Center and Yuma Test Center.

¹⁶ ГОСТ РВ 52048-2003. Автомобили многоцелевого назначения. Параметры проходимости и методы их определения.

Fig. 5. Transverse section of the 30 percent side slope.



Fig. 6. Illustration of the 30 percent side slope.

Table 2.

Orientation project data of the side slopes.

No	Side slope (percent)	Carriageway length (m)	Material used for road cover
1	20	83	concrete
2	30	220	concrete
3	40	91	concrete

A vertical-sided ditches (fig 7,a), vertical walls (fig 7,b) and vertical steps (fig 7,c) are arranged on a flat, level area, with hard cover as an assemble of various construction of different sizes. It is permissible to construct them from concrete. Dimensions of area must be suitable for complete overcoming of obstacles by vehicle. The length of every ditch must be no less than 4 m. The depth (h) of ditches must be selected in such a way so that when overcoming them by vehicle the wheels must not touch the

ditch bottom. The length of each vertical wall and vertical step must be no less than 4 m. The breadth of vertical wall does not exceed its height ($a \leq h$).^{17,18}

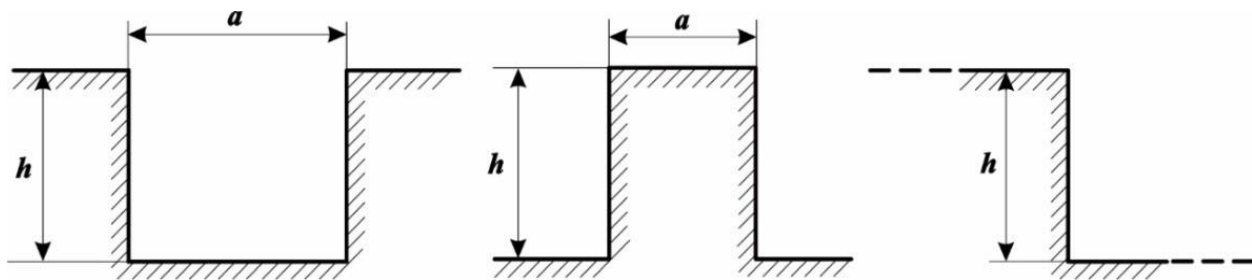

Fig. 7. Schemes of vertical-sided ditches (a), vertical walls (b) and vertical steps (c).

The vertical wall (Fig. 8) can be equipped with replaceable timbers at the top so that the wall can be maintained in a standard condition following damage from tests. Orientation scheme of arrangement of vertical steps with different height is given on figure 9.¹⁶



Fig. 8. Vehicle ascending the vertical wall.

¹⁷ AVTP 03-80. Standard obstacles.

¹⁸ ГОСТ РВ 52048-2003. Автомобили многоцелевого назначения. Параметры проходимости и методы их определения. 16 TOP 01-1-011A. Vehicle Test Facilities at Aberdeen Test Center and Yuma Test Center.

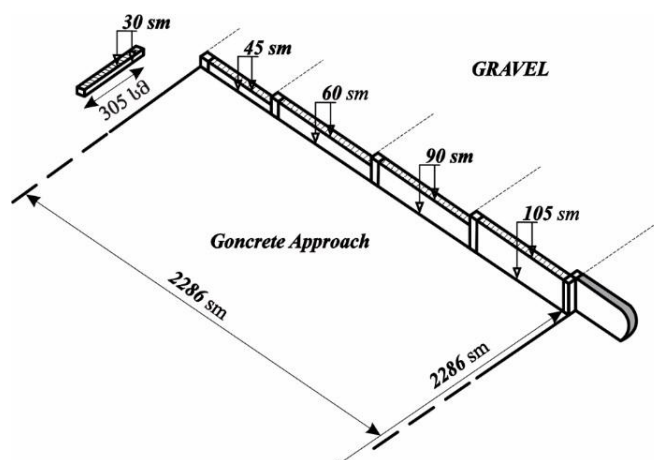
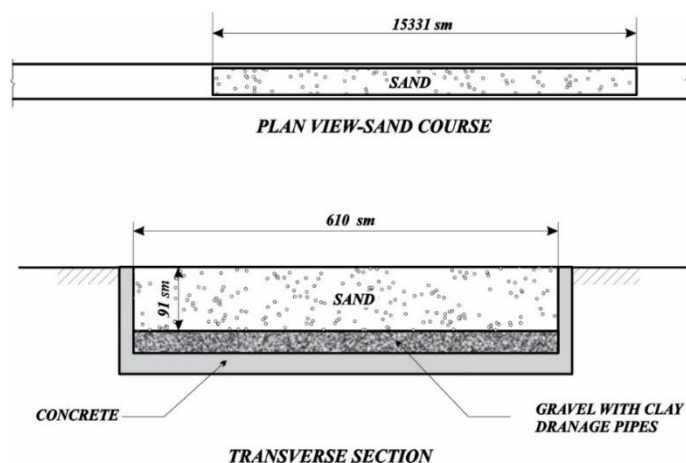

Fig. 9. Isometric view of the vertical walls.

The sand course is used during soft soil mobility of vehicle for determining the drawbar pull, speed and acceleration. The figure 10 shows project data of the sand course. Besides the above mentioned, the given parameters can be determined for fine-grained soil (for example loam, clay) as well as for natural terrain, as required. Parameters of testing areas (length, width) must not be less than parameters of sand course. Besides, there should be the means of irrigation and tilling in the depth to approximately 60 cm on the area of fine-grained soil. For irrigation, analogical construction can be used as given on figure 11.^{19,20,21}



¹⁹ AVTP 03-100. Soft Soil Mobility.

²⁰ TOP 01-1-011A. Vehicle Test Facilities at Aberdeen Test Center and Yuma Test Center.

²¹ ГОСТ РВ 52048-2003. Автомобили многоцелевого назначения. Параметры проходимости и методы их определения.

Fig. 10. Plan view and transverse section of sand course.



Fig. 11. Mud bypass course with sprinklers operating.

Project schemes of the basins for fording tests of the vehicles are given on figure 12 and figure 13. The bottom of the basin is made of compacted sandy crushed stone or concrete. Length of basin area with the equal depth must not be less than three times overall length of the vehicle. After coming out of the water, it must be possible to functionally check steer control and braking ability of the vehicle.^{22,23,24}

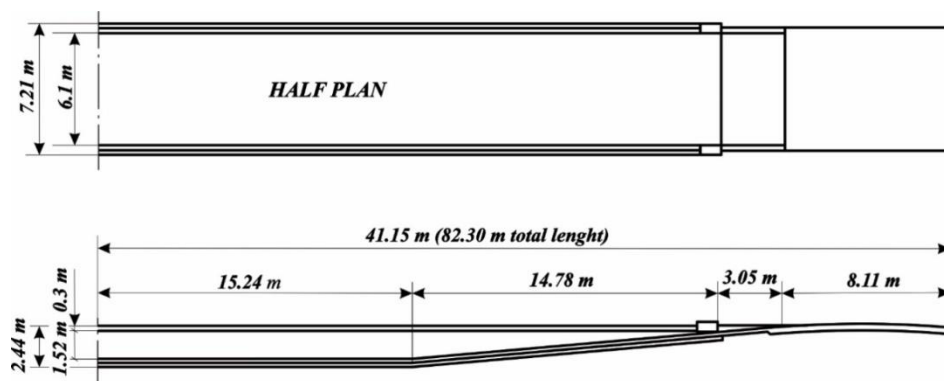

²² AVTP 03-110. Fording.

²³ TOP 2-2-612. Fording.

²⁴ ГОСТ РВ 52048-2003. Автомобили многоцелевого назначения. Параметры проходимости и методы их определения.

Fig.12. Half plan and section views of the fording basin

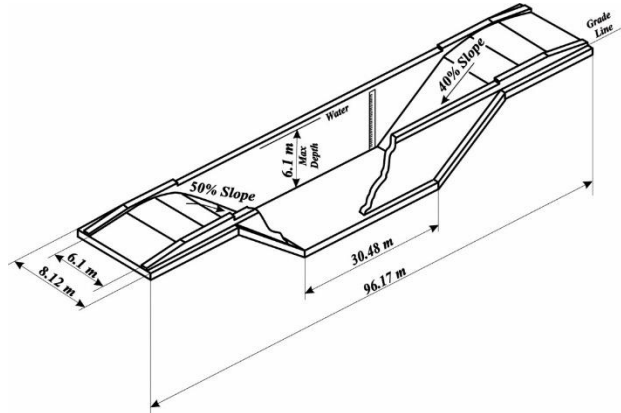

Fig.13. Underwater fording facility.

CONCLUSION

Thus, on the basis of corresponding normative documentation intended for military vehicles of USA and Russian Federation, the project schemes of building construction for estimation of passability of military vehicles have been developed. Mentioned schemes can be used for building the proving ground passability constructions and for checking the passability parameters of military vehicles by means of comparative estimation, which are obligatory in the frame of North Atlantic Treaty Organization.

REFERENCES:

1. Dvali R. Theory of operational properties of the vehicle. Tbilisi, Tbilisi University Publishing House, 1986
2. AVTP 1. Allied vehicle testing publications.
3. AVTP 01-10. Dimension and profile 4. AVTP 03-30. Steering and Manoeuvrability.
5. AVTP 03-80. Standard obstacles.
6. AVTP 03-90. Gradients and Slopes.
7. AVTP 03-100. Soft Soil Mobility.
8. AVTP 03-110. Fording.
9. TOP 01-1-011A. Vehicle Test Facilities at Aberdeen Test Center and Yuma Test Center.
10. TOP 2-2-612. Fording.
11. Агейкин Я. С. Проходимость автомобилей. М.: Машиностроение, 1981.
12. ГОСТ РВ 52048-2003. Автомобили многоцелевого назначения. Параметры проходимости и методы их определения.